

SciCam-Microscope (SCM)

Digital USB3.0 Camera

Systems

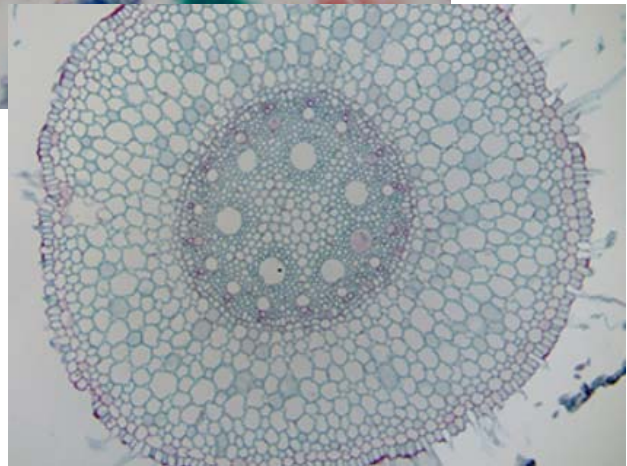
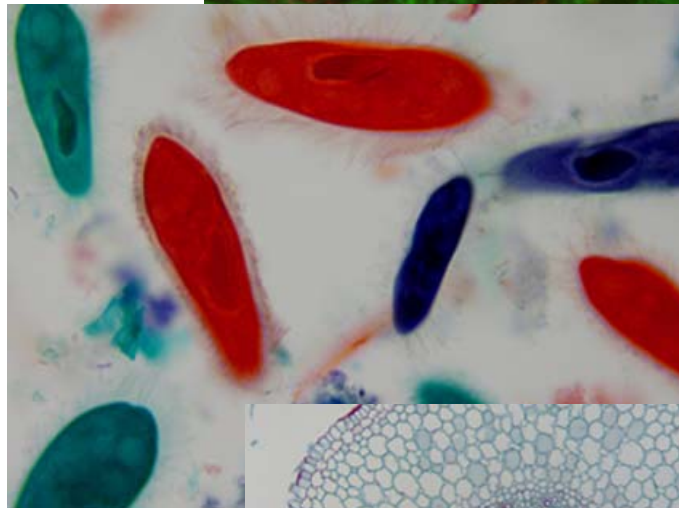
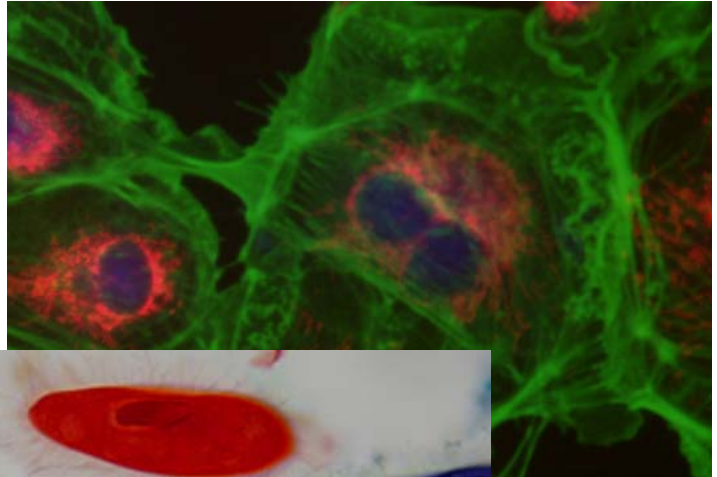
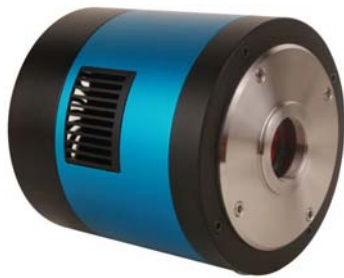

Scientific Grade Microscope Cameras

SCM -TE cooled Systems



The SCM-series scientific grade TE-cooled camera systems combine High Tech capabilities in a small housing. The cameras are designed and manufactured for outstanding long life in most demanding conditions. A wide variety of Sony ExView-HADsensors are available. The 14 Bit A/D conversion guarantee high resolution, low noise images of very high quality. The max. cooling temperature (dT) will be achieved shortly without water assistance.

For low vibration applications the fan speed can be controlled.

Fast data transfer will be provided through the industry standard USB3.0 Interface.

Acquisition Software EHDView will be provided as well as a free Windows/Linux/MacOS

Multiple platform SDK. The camera can also be controlled via Directshow and TWAIN.



Key Features:

- ◆ Sensor cooling max. dT 45°C
- ◆ Two-Stage Peltier Cooler
- ◆ 14 Bit Digitization
- ◆ Controllable fan
- ◆ Wide variety of sensors available
- ◆ Very low noise imaging
- ◆ Color and monochrome imaging
- ◆ Advance image processing EHDView
- ◆ External Trigger

OTHER HARDWARE CONFIGURATION	
Spectral Range	380-650nm (with IR-filter)
White Balance	ROI White Balance/ Manual Temp-Tint Adjustment
Color Rendering Technique	Ultra Fine Color Engine
Capture/Control API	Native C/C++, C#, Directshow, Twain, Labview
Recording System	Still Picture and Movie
Cooling System*	Two-stage TE-cooling System -45 °C below Camera Body Temperature
OPERATING ENVIRONMENT	
Operating Temperature	-10°C~ 50°C
Storage Temperature	-20°C~ 60°C
Operating Humidity	30~80%RH
Storage Humidity	10~60%RH
Power Supply	DC 5V over PC USB Port External Power Adapter for Cooling System, DC12V, 3A
SOFTWARE ENVIRONMENT	
Operating System	Support Microsoft Windows XP / Vista / 7 / 8 / 10 (32 & 64 bit) OS X (Mac OS X), Linux
PC Requirements	CPU: Equal to Intel Core2 2.8GHz or Higher
	Memory: 2GB or More
	USB port: USB2.0 High-speed Port
	Display: 17" or Larger
	CD-ROM

SCM Systems



The SCM-series Microscopy camera systems combine High Tech capabilities in a small housing. The cameras are designed and manufactured for outstanding long life in most demanding conditions. A wide variety of Sony EXMOR backilluminated CMOS sensors up to 12 Megapixel are available. The 14 Bit A/D conversion guarantee high resolution, low noise images of very high quality without the need of cooling.

Fast data transfer will be provided through the industry standard USB3.0 Interface.

Acquisition Software EHDView will be provided as well as a free Windows/Linux/MacOS

Multiple platform SDK. The camera can also be controlled via Directshow and TWAIN.



Key Features:

- ◆ Backilluminated Sony EXMOR sensors
- ◆ Super High sensitivity up to 1120mV
- ◆ 14 Bit Digitization
- ◆ Wide variety of sensors available
- ◆ Ultra low noise imaging
- ◆ Color and monochrome imaging
- ◆ Advance image processing EHDView
- ◆ Native C/C++, C#/VB.Net, DirectShow, TWAIN, LabView
- ◆ External Trigger

OTHER HARDWARE CONFIGURATION	
Spectral Range	380-650nm (with IR-filter)
White Balance	ROI White Balance/ Manual Temp-Tint Adjustment
Color Rendering Technique	Ultra Fine Color Engine
Capture/Control API	Native C/C++, C#, Directshow, Twain, Labview
Recording System	Still Picture and Movie
Cooling System*	Natural
OPERATING ENVIRONMENT	
Operating Temperature	-10°C~ 50°C
Storage Temperature	-20°C~ 60°C
Operating Humidity	30~80%RH
Storage Humidity	10~60%RH
Power Supply	DC 5V over PC USB Port
SOFTWARE ENVIRONMENT	
Operating System	Support Microsoft Windows XP / Vista / 7 / 8 (32 & 64 bit) OS X (Mac OS X), Linux
PC Requirements	CPU: Equal to Intel Core2 2.8GHz or Higher
	Memory: 2GB or More
	USB port: USB2.0 High-speed Port
	Display: 17" or Larger
	CD-ROM

SCM- TE Dimensions

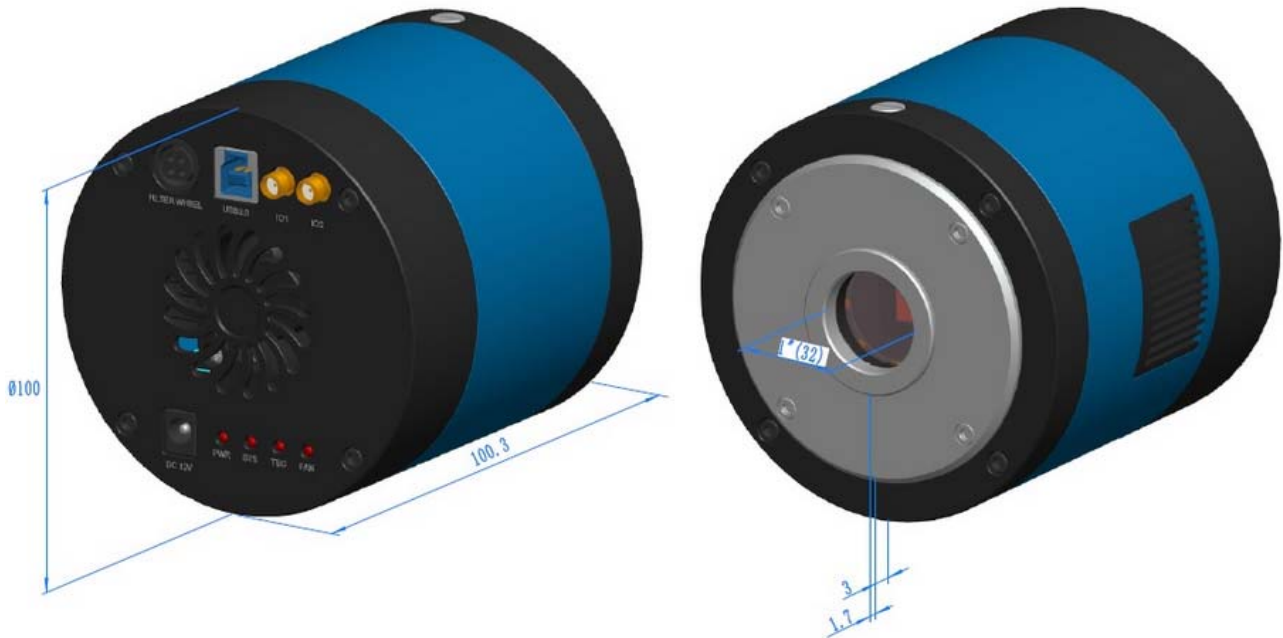

SCM- Dimensions

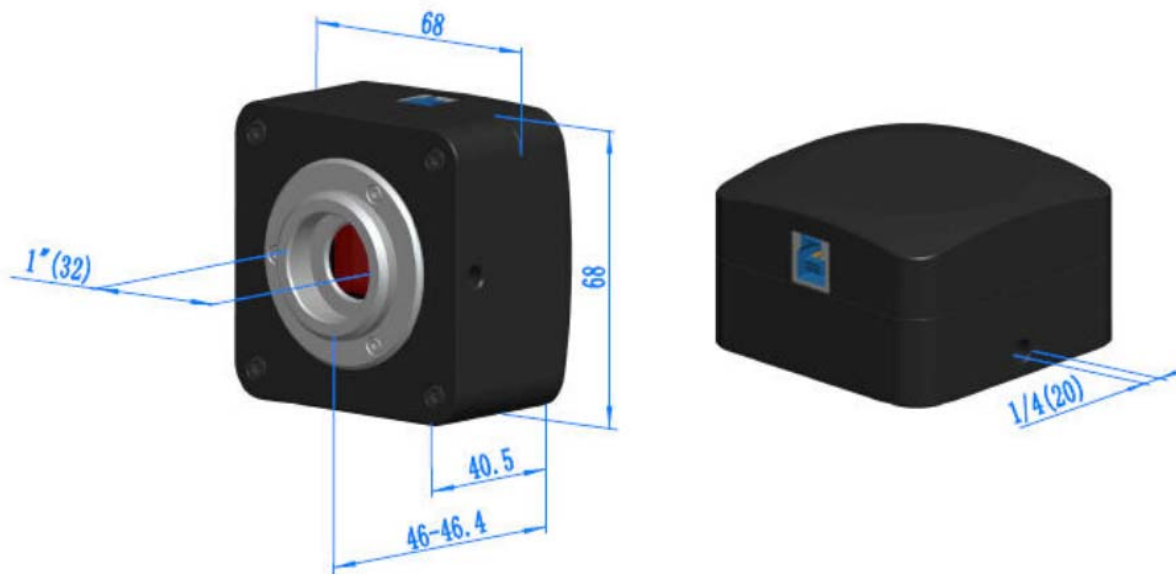

All dimensions in mm

SciCam Microscope Camera Systems

Type	Sensor	Pixel (H x V)	Pixelsize (μm)	Sensor Format (Zoll)	Sensor Size (mm)	Sensor Diag. (mm)	Frames/s fps @ full res.	Cooling dT (K)	Dark Signal 1/30s acc. (mV)	Exposure (ms)
SCM TE cooled Interline Sony EXView HAD Sensor Systems										
SCM694TE-C	ICX694 Color	2748 x 2200	4,54 x 4,54	1	14.6 x 12.8	19,4	7.5	45	8	0.06ms—1h
SCM694TE-M	ICX694 Mono	2728 x 2200	4,54 x 4,54	1	14.6 x 12.8	19,4	7.5	45	8	0.06ms—1h
SCM674TE-C	ICX674 color	1940 x 1460	4,54 x 4,54	2/3	10.7 x 9.2	14	15	45	4	0.05ms—1h
SCM674TE-M	ICX674-Mono	1940 x 1460	4,54 x 4,54	2/3	10.7 x 9.2	14	15	45	4	0.05ms—1h
SCM825TE-C	ICX825 Color	1360 x 1024	6,45 x 6,45	2/3	10.7 x 8.7	13,8	15	45	4,8	0.07ms—1h
SCM825TE-M	ICX825 Mono	1360 x 1024	6,45 x 6,45	2/3	10.7 x 8.7	13,8	15	45	4,8	0.07ms—1h

SCM Sony backilluminated EXMOR CMOS Sensor Systems

SCM226-C	IMX226 Color	4000 x 3000	1.85 x 1.85	1/1.7	7.4 x 5.55	9,33	7.1	None	0,1	0.244ms—2s
SCM178-C	IMX178 Color	3072 x 2048	2.4 x 2.4	1/1.8	7.37 x 4.92	8,92	15	None	0,15	0.244ms—2s
SCM178-M	IMX178 Mono	3072 x 2048	2.4 x 2.4	1/1.8	7.37 x 4.92	8,92	15	None	0,15	0.244ms—2s
SCM123-C	IMX123 Color	2048 x 1536	2.5 x 2.5	1/2.8	5.12 x 3.8	6,46	25	None	0,15	0.244ms—2s
SCM185-C	IMX185 Color	1920 x 1200	3.75 x 3.75	1/1.9	7.2 x 4.5	8,58	38	None	0,15	0.244ms—2s
SCM302-C-GS	IMX302 Color	1920 x 1200	5.86 x 5.86	1/1.2	11.25 x 7.0	13,4	30	None	0,15	0.244ms—2s
SCM174-M-GS	IMX174 Mono	1920 x 1200	5.86 x 5.86	1/1.2	11.25 x 7.0	13,4	30	None	0,15	0.244ms—2s
SCM250-C-GS	IMX250 Color	2448 x 2048	3.45 x 3.45	2/3	8.4 x 7.0	11	15	None	0,15	0.244ms—2s
SCM250-M-GS	IMX250 Mono	2448 x 2048	3.45 x 3.45	2/3	8.4 x 7.0	11	15	None	0,15	0.244ms—2s

Back-illuminated structure provides higher sensitivity

Sony's Image Sensor Exmor R is the back-illuminated CMOS image sensor with improved sensitivity and noise reduction - the key factors to enhancing image quality, while radically realigning their fundamental pixel structure from front-illumination to back-illumination. It has retained the advantages of CMOS image sensors such as low power consumption and high-speed operation.

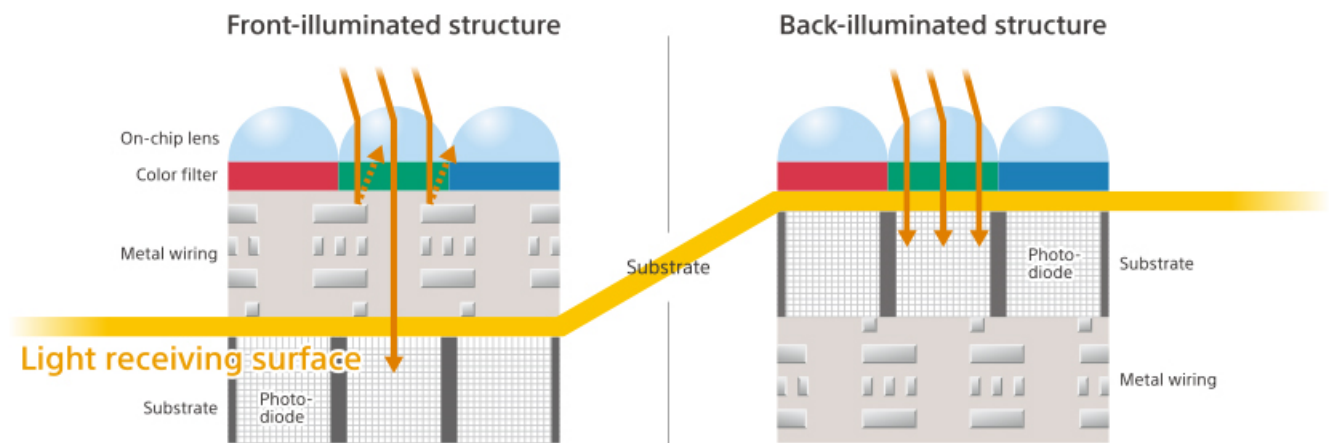

With a conventional front-illumination structure, the metal wiring and transistors on the surface of the silicon substrate that form the sensor's light-sensitive area (photo-diode) impede photon gathering carried out by the on-chip lens, and this has also been an important issue in the miniaturization of pixels and widening optical angle response. A back-illuminated structure minimizes the degradation of sensitivity to optical angle response, while also increasing the amount of light that enters each pixel due to the lack of obstacles such as metal wiring and transistors that have been moved to the reverse of the silicon substrate. However, compared to conventional front-illuminated structures, back-illuminated structures commonly causes p and also cause a decrease in the signal-to-noise ratio. To overcome this Sony has newly developed a unique photo-diode structure and on-chip lens optimized for back-illuminated structures, that achieves a higher sensitivity and a lower random noise without light by reducing noise, dark current and defect pixels compared to the conventional front-illuminated structure. Additionally, Sony's advanced technologies such as high-precision alignment have addressed any color mixture problems.