

User Manual for Machine Vision Cameras with EF Mount Lenses SCCxxxAFU-EF



20240511



Contents

USER MANUAL FOR MACHINE VISION CAMERAS WITH EF MOUNT LENSES	1
1 INTRODUCTION TO EHD MACHINE VISION CAMERAS	4
1.1 PRODUCT DESCRIPTION	4
1.2 CHARACTERISTICS.....	4
1.3 SCCXXXAFU-EF SERIES CAMERA SPECIFICATIONS (APS OR FULL FRAME, 4).....	4
1.4 CAMERA LENS ADAPTATION	5
2 SCCXXX-AFU-EF SERIES TECHNICAL SPECIFICATIONS(4)	9
2.1 SCC26000KMA-AFU-EF	9
2.2 SCC26000KPA-AFU-EF.....	10
2.3 SCC60000KMA-AFU-EF	11
2.4 SCC60000KPA-AFU-EF.....	12
3 CAMERA DIMENSION AND INTERFACE	13
3.1 SCCXXX-AFU-EF SERIES	13
3.1.1 <i>SCCXXX-AFU-EF Series Camera Mechanical Housing Dimensions</i>	13
3.1.2 <i>SCCXXX-AFU-EF Series Camera Interface</i>	14
3.1.3 <i>SCCXXX Series Camera Power Supply and I/O Connector</i>	14
3.1.4 <i>Packing Information</i>	14
4 ELECTRICAL CHARACTERISTICS	15
4.1 SCC SERIES CAMERA’S I/ O ELECTRICAL PROPERTIES	15
4.1.1 <i>Opto-isolated Input Circuit (line0)</i>	15
4.1.2 <i>Opto-isolated Output Circuit(line1)</i>	15
4.1.3 <i>Input and Output I/O Circuit(line2/line3)</i>	16
5 DESCRIPTION OF FUNCTIONS	23
5.1 CAMERA CAPTURE MODE.....	23
5.2 ROI CONTROL	23
5.3 AUTO FOCUS.....	23
5.4 BANDWIDTH AND PRECISE FRAME RATE CONTROL.....	23
5.4.1 <i>Bandwidth</i>	23
5.4.2 <i>Precise Frame Rate Control</i>	24
5.5 DDR3 BUFFER	24
5.6 BINNING	24
5.7 DC12V POWER SUPPLY AND COOLING SYSTEM	24
6 TRIGGER MODE AND ITS CONFIGURATION	25
6.1 VIDEO MODE AND TRIGGER MODE	25
6.2 TRIGGER SOURCES AND THEIR CAPTURE STYLE.....	25
6.3 THE TRIGGER CAPTURE AND IO CONTROL CONFIGURATIONS	27
7 COOLING	32
8 APPLICATION	33
8.1 APPLICATION INSTALLATION	33
8.2 INTRODUCTION TO TOUPVIEW.....	33
8.2.1 <i>User interface design</i>	33
8.2.2 <i>Professional Camera Control Sidebar</i>	33

8.2.3	<i>Professional and practical image processing functions</i>	34
8.2.4	<i>Super compatibility</i>	34
8.2.5	<i>Basic hardware requirements</i>	34
9	SOFTWARE DEVELOPMENT INSTRUCTIONS	35
9.1	SDK DESCRIPTION	35
9.1.1	<i>SDK support platform</i>	35
9.1.2	<i>Introduction to SDK content</i>	35

1 Introduction to EHD SCC machine vision cameras

1.1 Product Description

The cameras mentioned in this manual are imaging capture devices which use USB3.0 to transmit uncompressed images in real time. They support image acquisition and parameter setting (such as working mode, image parameter adjustment etc.) through client-side user-friendly software. The chip sizes of the SCCXXX-AFU-EF series of cameras are primarily APS or full-frame, and the cameras support control of Canon mount for autofocus.



Figure 1-1 SCCXXX-AFU-EF series cameras

1.2 Characteristics

- Sony Exmor back-illuminated CMOS sensor; Some cameras also use GPixel series sensors and domestic sensors.
- USB 3.0 data transmission interface compatible with USB2.0 protocol;
- Provides advanced video and image processing application software ToupView, compatible with Windows/Linux/OSX multi-platform SDK, support native C/C++, C#/VB.Net, DirectShow, Twain API;
- Supports external triggering, software and capture modes;
- Supports ROI, flip, bit-depth switching and other features;
- Supports EF/EF-S mount lens control and autofocus;
- Supports firmware worksite upgrading;
- Compliant with CE, FCC requirements.

1.3 SCCXXXAFU-EF Series Camera Specifications (APS or full frame, 4)

Model Number	Image Sensor	Pixel Size(μm)	G Sensitivity/Dark Signal	FPS/Resolution	Binning	Exposure Time
SCC26000KMA-AFU-EF	26.0M/IMX571BLR(M, RS) 1.8" (23.48x15.67, APS-C)	3.76x3.76	870.9mv with 1/30s 0.07mv with 1/30s	14fps@6224×4168(16bit) 37fps@3104×2084 110fps@2064×1388	1x1 2x2 3x3	150us~15s
SCC26000KPA-AFU-EF	26.0M/IMX571BQR(C, RS) 1.8" (23.48x15.67, APS-C)	3.76x3.76	484.5mv with 1/30s 0.07mv with 1/30s	14fps@6224×4168(16bit) 37fps@3104×2084 110fps@2064×1388	1x1 2x2 3x3	150us~15s
SCC60000KMA-	60.0M/IMX455ALK (M,	3.76x3.76	870.9mv with 1/30s	6.1fps@9568×6380(16bit)	1x1	150us~15s

AFU-EF	RS) 2.7" (35.96x23.99, Full Frame)		0.04mv with 1/30s	24.6fps@4784×3190 55.8fps@3184×2124 191.0fps@1040×706	2x2 3x3 9x9	
SCC60000KPA-AFU-EF	60.0M/IMX455AQK (C, RS) 2.7" (35.96x23.99, Full Frame)	3.76x3.76	484.5mv with 1/30s 0.07mv with 1/30s	6.1fps@9568×6380(16bit) 24.6fps@4784×3190 55.8fps@3184×2124 191.0fps@1040×706	1x1 2x2 3x3 9x9	150us~15s

M: Monochromatic; C: Color; RS: Rolling Shutter; GS: Global Shutter.

1.4 Camera Lens Adaptation

SCCXXX-AFU-EF series cameras can be used with EF-mount lenses. When the lens is correctly mounted, you can read the lens focal length, aperture, focus, and other information, and you can control the lens aperture and focus electrically.

Verify that the adapted EF-mount lens models and functions are as follows:

Lens	Closest Focusing Distance	Aperture Control	Focus Control	Fixed Distance Focusing
Canon EF-S 10-18mm f/4.5-5.6 IS STM	About 0.22m	Support	Support	/
Canon EF-S 18-55mm f/3.5-5.6 IS STM	About 0.25m	Support	Support	Support
Canon EF-S 18-55mm f/4-5.6 IS STM	About 0.25m	Support	Support	/
Canon EF-S 15-85mm f/3.5-5.6 IS USM	About 0.35m	Support	Support	/
Canon EF-S 18-135mm f/3.5-5.6 IS USM	About 0.39m	Support	Support	Support
Canon EF-S 18-200mm f/3.5-5.6 IS	About 0.45m	Support	Support	/
Canon EF 24mm f/1.4L II USM	About 0.25m	Support	Support	/
Canon EF 24mm f/2.8 IS USM	About 0.2m	Support	Support	/
Canon EF 35mm f/1.4L II USM	About 0.28m	Support	Support	/
Canon EF 50mm f/1.2L USM	About 0.45m	Support	Support	Support
Canon EF 50mm f/1.4 USM	About 0.45m	Support	Support	/
Canon EF 85mm f/1.2L II USM	About 0.95m	Support	Support	/
Canon EF 16-35mm f/2.8L III USM	About 0.28m	Support	Support	/
Canon EF 16-35mm f/4L IS USM	About 0.28m	Support	Support	/
Canon EF 24-70mm f/2.8L II USM	About 0.38m (Macro mode is about 0.2m)	Support	Support	/
Canon EF 24-70mm f/4L IS USM	About 0.38m (Macro mode is about 0.2m)	Support	Support	/
Canon EF 24-105mm f/4L IS USM	About 0.45m	Support	Support	/
Canon EF 100-400mm f/4.5-5.6L IS II USM	About 0.98m	Support	Support	/
Sigma 150-600mm f/5-6.3 DG OS HSM S	About 2.6m	Support	Support	/

Note: This camera theoretically supports any EF mount lens, but not all lenses have been tested. Use of lenses from manufacturers other than Canon may be uncontrollable or incompatible. If you need other lenses, please point out the model number of the desired lens, we will do a good job of testing for you.



Figure 1-2 Canon EF lenses currently supported by the SCCXXX-AFU-EF camera



Figure 1-3 SCCXXX-AFU-EF camera with Canon EF lenses



Figure 1-4 SCCXXX-AFU-EF camera, Canon EF lenses with TPS-600 fine focus bracket



Figure 1-5 SCCXXX-AFU-EF camera, Canon EF lenses with TPS-600 fine focus bracket



Figure 1-6 SCCXXX-AFU-EF camera, Canon EF lenses with TPS-600 fine focus bracket



Figure 1-7 Product illustration of machine vision cameras with EF lenses

2 SCCXXX-AFU-EF Series Technical

Specifications(4) 2.1 SCC26000KMA-AFU-EF

Table 2-1 SCC26000KMA-AFU-EF camera specifications

Parameter	Model
	SCC26000KMA-AFU-EF
26.0M pixels 1.8" (APS-C) CMOS USB3.0 industrial camera	
Camera	
Sensor model	Sony IMX571BLR-J
Pixel size	3.76 μm x 3.76 μm
Sensor size	1.8" (APS-C)
Frame rate	14fps@6224 x 4168(16bit), 37fps@3104 x 2084, 110fps@2064 x 1388
Dynamic range	86.8dB
Signal-to-Noise ratio	47.1dB
Sensitivity	870.9mv
Dark current	0.07mv
Gain range	1x-50x
Exposure time	150us-15sec
Shutter	Rolling shutter
Binning	Hardware 2x2, 3x3; Software 2x2, 3x3, 4x4
Data interface	USB3.0 (USB3.1 GEN1)
Digital I/O	One optical-coupling isolated input, one optical-coupling isolated output, two non-isolated input and output
Data Format	8bit / 16bit
General Specifications	
Power supply	12V Power adapter
Power consumption	<5.0W
Temperature	Working temperayure-10~50°C, storage temperature-30~70°C
Humidity	20%-80%, no condensation
Size	88mmx88mmx21.2mm
Weight	540g
Lens mount	M42 Interface
Software	EHDView/ SDK
Platform and architecture	Win32/WinRT/Linux/macOS/Android; X86/X64/armhf/armel/arm64
Certification	CE, FCC

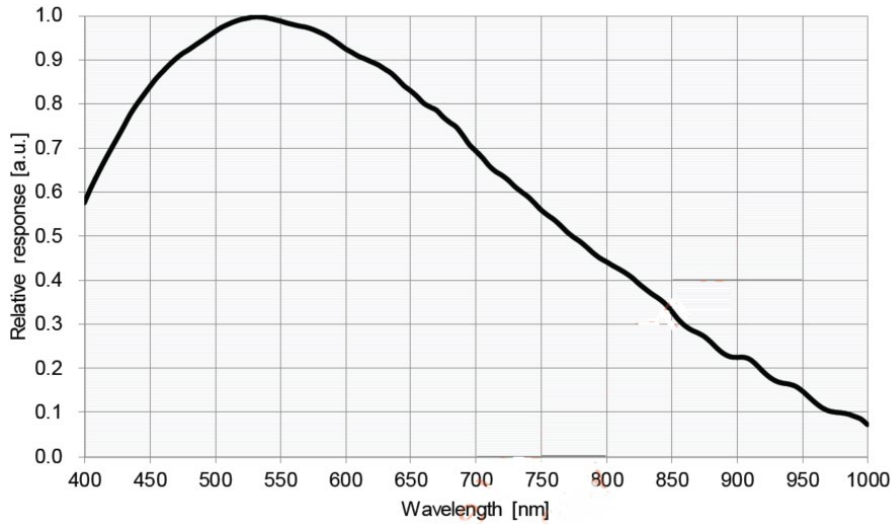

Figure 2-1 SCC26000KMA-AFU-EF spectral response curve

2.2 SCC26000KPA-AFU-EF

Table 2-2 SCC26000KPA-AFU-EF camera specifications

Parameter	Model
	SCC26000KPA-AFU-EF
26.0M pixels 1.8" (APS-C) CMOS USB3.0 industrial camera	
Camera	
Sensor model	Sony IMX571BQR-C
Pixel size	3.76 μm x 3.76 μm
Sensor size	1.8" (APS-C)
Frame rate	14fps@6224 x 4168(16bit), 37fps@3104 x 2084, 110fps@2064 x 1388
Dynamic range	86.8dB
Signal-to-Noise ratio	47.1dB
Sensitivity	484.5mv
Dark current	0.07mv
Gain range	1x-50x
Exposure time	150us-15sec
Shutter	Rolling shutter
Binning	Hardware 2x2, 3x3; Software 2x2, 3x3, 4x4
Data interface	USB3.0 (USB3.1 GEN1)
Digital I/O	One optical-coupling isolated input, one optical-coupling isolated output, two non-isolated input and output
Data Format	8bit / 16bit
General Specifications	
Power supply	12V Power adapter
Power consumption	<5.0W
Temperature	Working temperayure-10~50°C, storage temperature-30~70°C
Humidity	20%-80%, no condensation
Size	88mmx88mmx21.2mm
Weight	540g
Lens mount	M42 Interface
Software	EHDView/ SDK
Platform and architecture	Win32/WinRT/Linux/macOS/Android; X86/X64/armhf/armel/arm64
Certification	CE, FCC

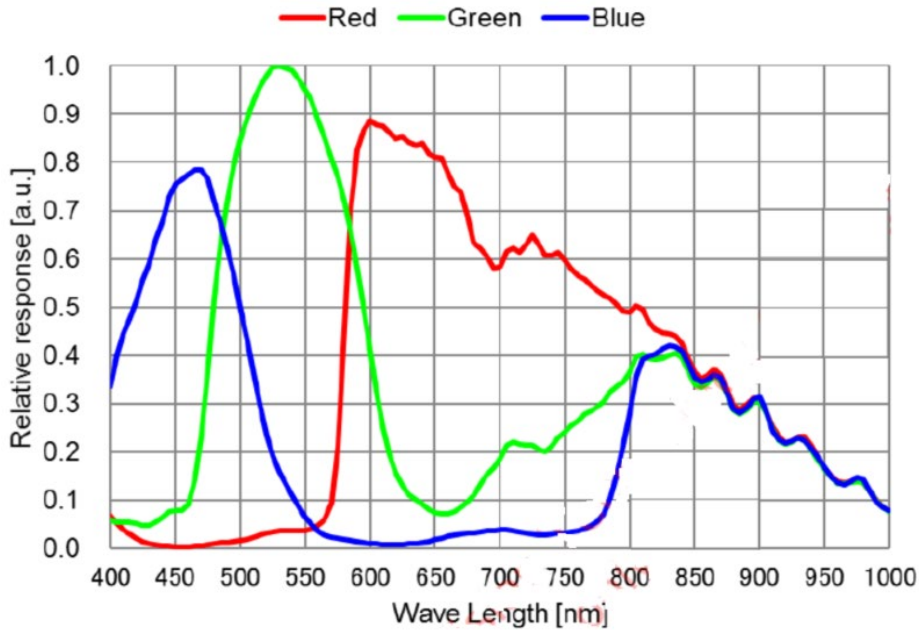

Figure 2-2 SCC26000KPA-AFU-EF spectral response curve

2.3 SCC60000KMA-AFU-EF

Table 2-3 SCC60000KMA-AFU-EF camera specifications

Parameter	Model
	SCC60000KMA-AFU-EF
60.0M pixels 2.7" (Full Frame) CMOS USB3.0 industrial camera	
Camera	
Sensor model	Sony IMX455ALK
Pixel size	3.76 μm x 3.76 μm
Sensor size	2.7" (Full Frame)
Frame rate	6.1fps@9568 x 6380(16bit), 24.6fps@4784 x 3190, 55.8fps@3184 x 2124, 191.0@1040 x 706
Dynamic range	88.3dB
Signal-to-Noise ratio	47.1dB
Sensitivity	870.9mV
Dark current	0.04mV
Gain range	1x-50x
Exposure time	150us-15sec
Shutter	Rolling shutter
Binning	Hardware 2x2, 3x3, 9x9; Software 2x2, 3x3, 9x9
Data interface	USB3.0 (USB3.1 GEN1)
Digital I/O	One optical-coupling isolated input, one optical-coupling isolated output, two non-isolated input and output
Data Format	8bit / 16bit
General Specifications	
Power supply	12V Power adapter
Power consumption	<5.5W
Temperature	Working temperayure-10~50°C, storage temperature-30~70°C
Humidity	20%-80%, no condensation
Size	88mmx88mmx21.2mm
Weight	540g
Lens mount	M52 Interface
Software	EHDView/ SDK
Platform and architecture	Win32/WinRT/Linux/macOS/Android; X86/X64/armhf/armel/arm64
Certification	CE, FCC

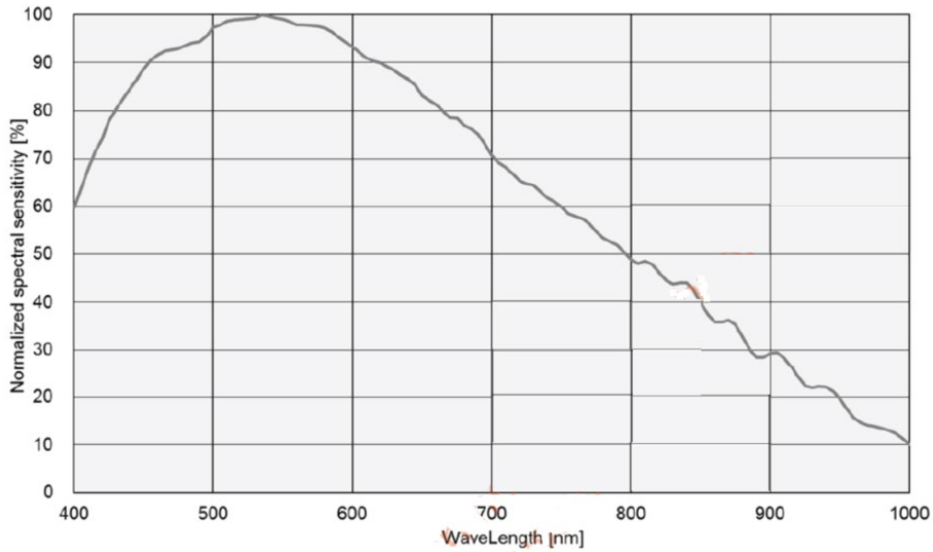

Figure 2-3 SCC60000KMA-AFU-EF spectral response curve

2.4 SCC60000KPA-AFU-EF

Table 2-4 SCC60000KPA-AFU-EF camera specifications

Parameter	Model
	SCC60000KPA-AFU-EF
60.0M pixels 2.7" (Full Frame) CMOS USB3.0 industrial camera	
Camera	
Sensor model	Sony IMX455AQK
Pixel size	3.76 μm x 3.76 μm
Sensor size	2.7" (Full Frame)
Frame rate	6.1fps@9568 x 6380(16bit), 24.6fps@4784 x 3190, 55.8fps@3184 x 2124, 191.0@1040 x 706
Dynamic range	85.8dB
Signal-to-Noise ratio	47.0dB
Sensitivity	484.5mV
Dark current	0.07mV
Gain range	1x-50x
Exposure time	150us-15sec
Shutter	Rolling shutter
Binning	Hardware 2x2, 3x3, 9x9; Software 2x2, 3x3, 9x9
Data interface	USB3.0 (USB3.1 GEN1)
Digital I/O	One optical-coupling isolated input, one optical-coupling isolated output, two non-isolated input and output
Data Format	8bit / 16bit
General Specifications	
Power supply	12V Power adapter
Power consumption	<5.5W
Temperature	Working temprayure-10~50°C, storage temperature-30~70°C
Humidity	20%-80%, no condensation
Size	88mmx88mmx21.2mm
Weight	540g
Lens mount	M52 Interface
Software	EHDView/ SDK
Platform and architecture	Win32/WinRT/Linux/macOS/Android; X86/X64/armhf/armel/arm64
Certification	CE, FCC

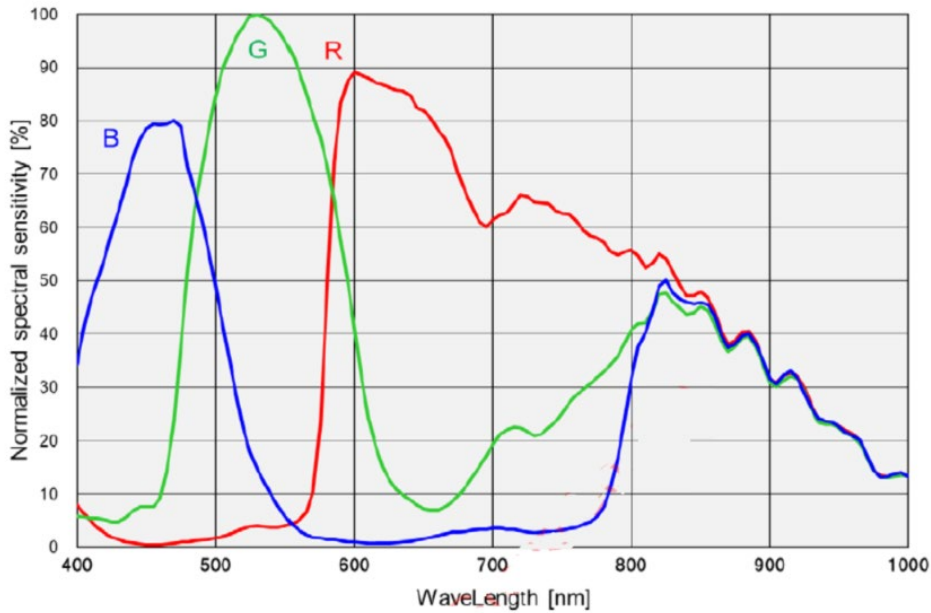

Figure 2-4 SCC60000KPA-AFU-EF spectral response curve

3 Camera Dimension and Interface

3.1 SCCXXX-AFU-EF Series

3.1.1 SCCXXX-AFU-EF Series Camera Mechanical Housing Dimensions



Figure 3-1 SCCXXX-AFU-EF series camera

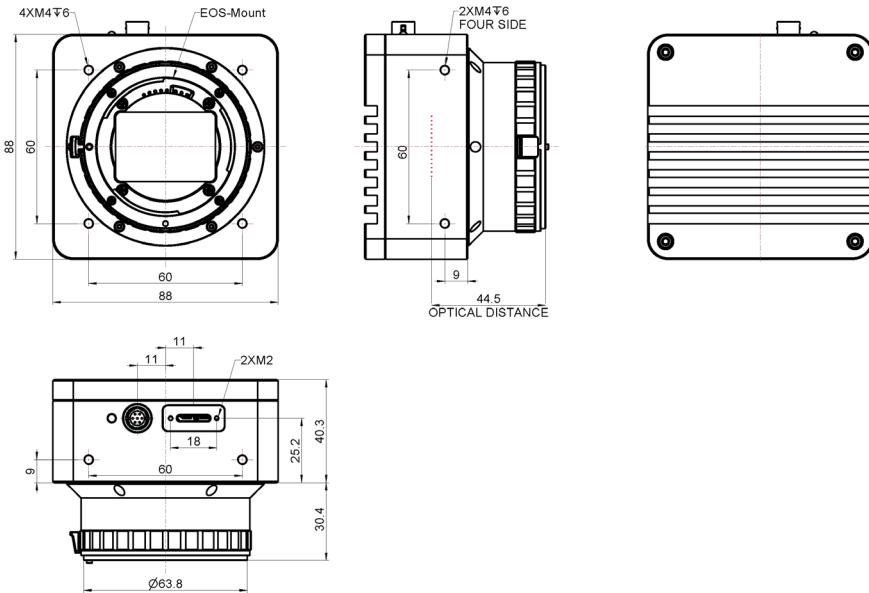

Figure 3-2 Dimensions of SCCXXX-AFU-EF camera housing (mm)

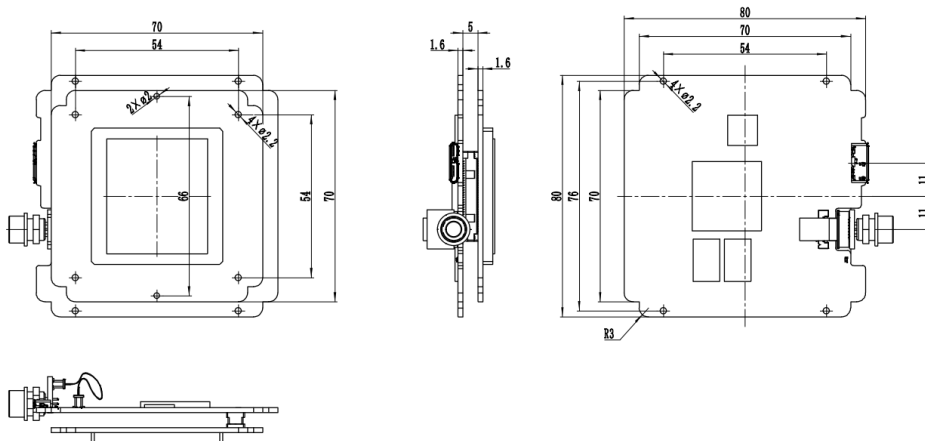

Figure 3-3 Dimensions of SCCXXX-AFU-EF circuit board (mm)

3.1.2 SCCXXX-AFU-EF Series Camera Interface

The back of the industrial camera is shown in Figure 3-4. It has standard USB3.0 output, 7 Pin I/O port (aviation head) and on/off indicator. It has two M2 screw holes on both sides of USB 3.0 port to fix the cable. The holes reduce cable loosening caused by field vibration.

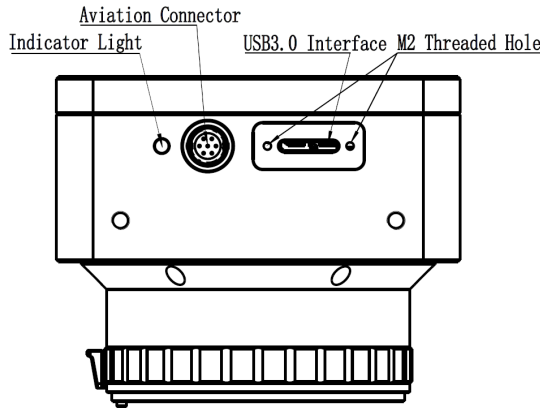
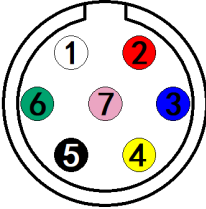

Figure 3-4 Schematic diagram of SCCXXX-AFU-EF camera back panel

3.1.3 SCCXXX Series Camera Power Supply and I/O Connector

The pin signal definition for the IUCXXX series camera 7 Pin I/O connector is shown in Table 3-1.

Table 3-1 IUC series pin signal definitions

	Color	Pin	Signal	Signal description
	White	1	GND	Direct-coupled signal ground
	Red	2	12V	5VDC power input or output
	Blue	3	OPTO_GND	Opto-isolated signal ground
	Yellow	4	DIR_GPIO0	Direct-coupled General Purpose I/O (Software configurable input/output) (line2)
	Black	5	DIR_GPIO1	Direct-coupled General Purpose I/O (Software configurable input/output) (line3)
	Green	6	OPTO_IN	Opto-isolated input signal (line0)
	Pink	7	OPTO_OUT	Opto-isolated output signal (line1)

3.1.4 Packing Information

For normal use of industrial cameras, please prepare the required accessories as shown in Table 3-2 before installation.

Table 3-2 Recommended accessories for SCC series camera

Order number	Accessories name	Quantity	Instruction
1	Camera	1	Camera referred in this manual
2	I/O cable	1	7 Pin cable or extended cable
3	USB3.0 cable	1	Suitable length of Micro USB3.0 cable
4	Power (IUC)	1	Power adapter for IUC series
5	Lens (optional)	1	C-mount lens

4 Electrical Characteristics

4.1 SCC Series Camera's I/ O Electrical Properties

4.1.1 Opto-isolated Input Circuit (line0)

In the camera I/O control, opto-isolated input circuit is shown in Figure 4-1.

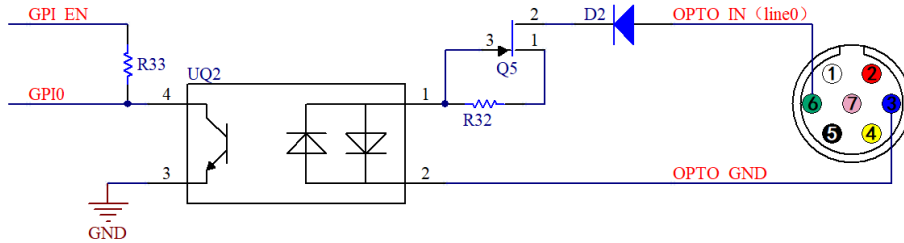

Figure 4-1 Opto-isolated input circuit

Logic 0 input level: 0~2.2VDC (OPTO_IN pin)

Logic 1 input level: 3.3~24VDC (OPTO_IN pin)

Maximum input current: 30mA

The input level is between 2.2V and 3.2V, the circuit action state is uncertain, please avoid the input voltage working in this range.

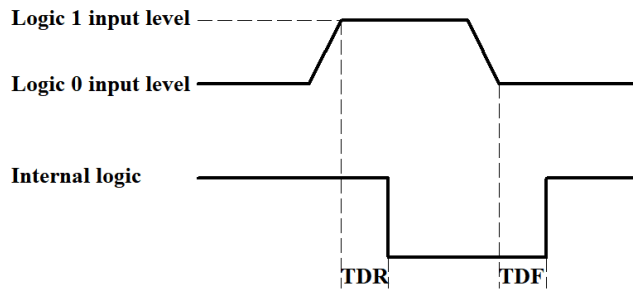

Figure 4-2 Input logic level

Input rise delay (TDR): 6us

Input drop delay (TDF): 6us

4.1.2 Opto-isolated Output Circuit(line1)

In camera I/O control, opto-isolated output circuit is shown in Figure 4-3.

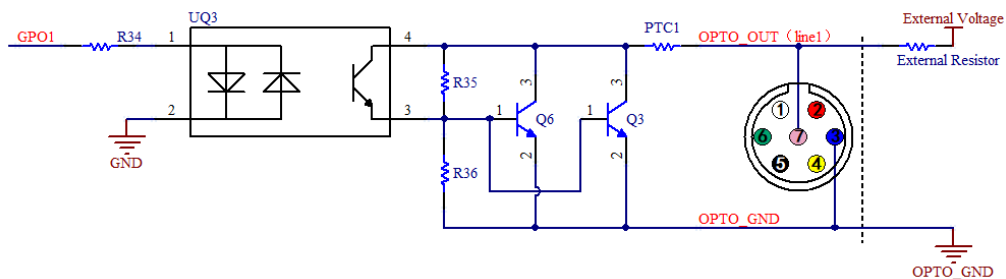

Figure 4-3 Opto-isolated output circuit

Opto-isolated output maximum current: 30mA

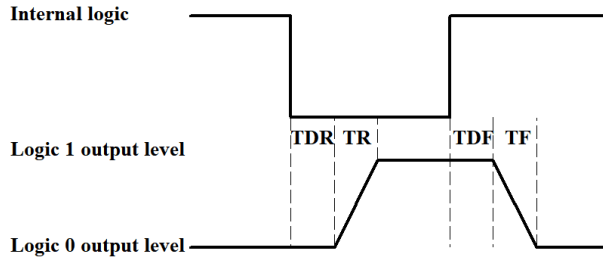

Figure 4-4 Output logic level

The electrical characteristics of the opto-isolated output signal (external voltage 5V, external resistor 1K) are shown in Table 4-1.

Table 4-1 Opto-isolated output signal's electrical characteristics

Parameter name	Parameter symbol	Parameter values
Output logic low level	VL	742mV
Output logic high	VH	4.134V
output rise time	TR	4us
Output downtime	TF	1.8us
Output rising delay	TDR	12us
Output drop delay	TDF	2us

The corresponding current and output logic low level parameters are shown in Table 4-2 when different voltage and resistors are used in external circuit.

Table 4-2 Opto-isolated output logic's low level parameters

External voltage	Non-essential resistance	VL	Output current
3.3V	1KΩ	510mV	2.82mA
5V	1KΩ	742mV	4.31mA
12V	2.4KΩ	795mV	4.68mA
24V	4.7KΩ	850mV	4.97mA

4.1.3 Input and Output I/O Circuit(line2/line3)

Non-isolated configurable input, output I/O circuit is shown in Figure 4-5, Figure 4-6.

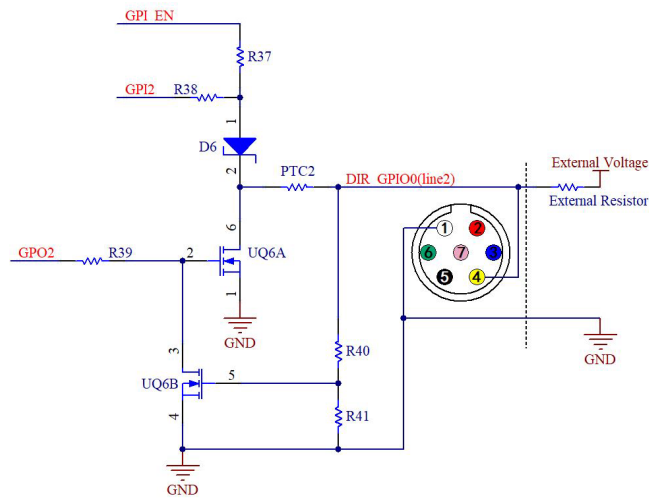

Figure 4-5 Non-isolated configurable input, output I/ O circuit (line2)

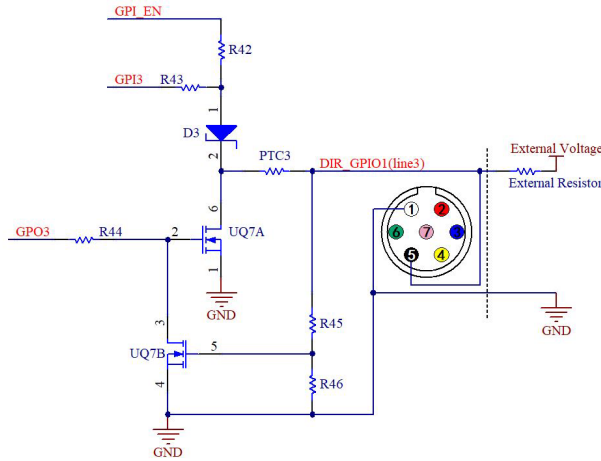

Figure 4-6 Non-isolated configurable input, output I/ O circuit (line3)

1, Line2/line3 set as input pin:

Logic 0 input level: 0-0.6 VDC (DIR_GPIO1/DIR_GPIO2 pin)

Logic 1 input level: 2.0~24VDC (DIR_GPIO1/DIR_GPIO2 pin)

Maximum input current: 25mA

The input level is between 0.6V and 2.0V, the circuit action state is uncertain. Please avoid the input voltage working in this range.

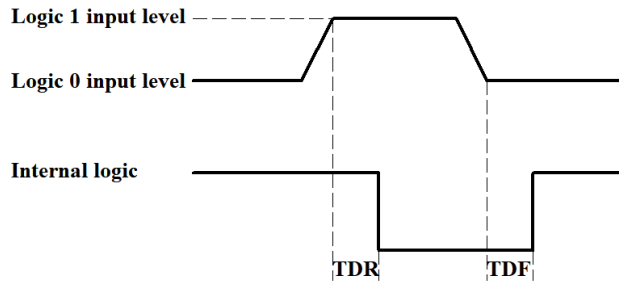

Figure 4-7 Input logic level

To prevent damage to the GPIO pin, connect the GND pin before entering voltage to the Line2 pin.

Input rise delay (TDR): 0.02us

Input drop delay (TDF): 0.02us

2, Line2/line3 set as output pin

The maximum current allowed through this pin is 25 mA.

When the ambient temperature is 25 degrees Celsius, the relationships between the external voltage, resistance and output low level are shown in Table 4-3.

Table 4-3 Non-isolated output logic's low level parameters

External voltage	Non-essential resistance	VL (GPIO)
3.3V	1KΩ	0.11V
5V	1KΩ	0.167V
12V	2.4KΩ	0.184V
24V	4.7KΩ	0.385V

The external pull-up voltage 5V pull-up resistance 1KΩ, GPIO output logic level, electrical characteristics are shown in Figure 4-8.

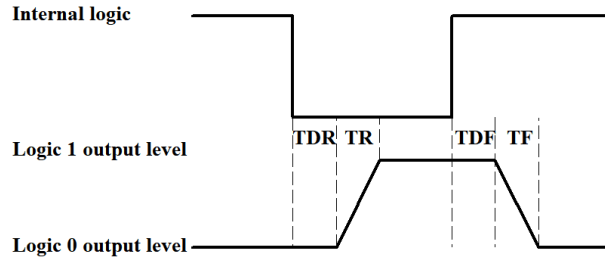

Figure 4-8 Output logic level

Table 4-4 Non-isolated output's electrical characteristics

Parameter name	Parameter symbol	Parameter values
Output rise time	TR	0.08us
Output downtime	TF	0.02us
Output rising delay	TDR	0.1us
Output drop delay	TDF	0.04us

5 Description of Functions

5.1 Camera Capture Mode

Camera operation mode support: Video Mode or Trigger Mode.

Camera trigger mode supports: Soft Trigger Mode(Software) or External Trigger Mode(Isolated input, GPIO0, GPIO1, Counter or PWM).

5.2 ROI Control

Partial cameras supports hardware ROI. The smaller the ROI size, the faster the frame rate.

5.3 Auto Focus

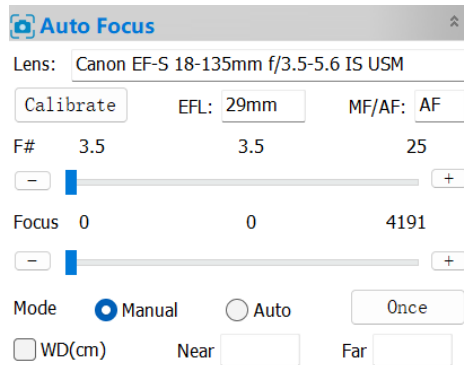

Figure 5-1 Lens control and autofocus

Lens Information	Lens	Lens Name .
	EFL	Lens effective focal length /mm.
	MF/AF	Check the status of the MF/AF button on the lens. Lens control is possible only when it is in the AF state.
Calibrate		When there is an error in the lens information, aperture range, or focus range, click on the Calibration to re-read it. The aperture will return to the maximum aperture after calibration, and the focus motor will return to the closest focus position and cause the system to reacquire the focus range.
Lens Control	"F#" control	Displays the current lens settable aperture range and allows the user to move the slider on the scroll bar with the mouse for aperture control . Note that when the focal length changes, the settable aperture range will also change.
	"Focus" control	Displays the current focus range of the lens. The user can change the focus position of the lens by dragging the slider on the focus slider with the mouse.
Focus Mode	Manual	Manual mode allows aperture and focus control via the slider or the "+" "-" buttons.
	Auto	The system will autofocus based on the current scene in the focus region until it is clear.
	Once	Click this button to perform a single autofocus operation on the focus region . Note that modifying the focus region restarts single focusing.
	WD (Fixed Distance)	Input the object distance range of the closest focusing distance and the farthest focusing distance in the text box, and perform autofocus within this range. Note that it is normal to perform this function without fixing the focus after zooming, and the fixing function will be performed once first. Not all lenses support the Fixed Distance Focus function.

5.4 Bandwidth and Precise Frame Rate Control

5.4.1 Bandwidth

Partial cameras supports bandwidth adjustment from 1% to 100%. As shown in Figure 5-2, the camera is with 100% bandwidth by default, and you can drag the slider to set the desired bandwidth.

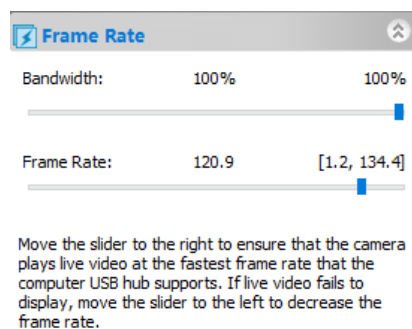

Figure 5-2 Bandwidth and precise frame rate settings

5.4.2 Precise Frame Rate Control

Partial cameras series supports precise frame rate control. The frame rate range will vary based on bandwidth, bit depth, resolution, ROI. As shown in Figure 5-2, the current frame rate can be set by dragging the Bandwidth or Frame Rate slider bar left or right.

5.5 DDR3 Buffer

Camera has a built-in 512MB (4Gb) DDR3 buffer, which can effectively improve the stability of USB3.0 data transmission and ensure that the camera does not lose frames when working.

5.6 Binning

Camera supports additive or averaged 1x1 to 8x8 digital binning, and averaged 1x1 to 2x2 hardware binning. Hardware binning can achieve higher frame rates than software binning.

6 Trigger Mode and its Configuration

6.1 Video Mode and Trigger Mode

The trigger function can be found on the **Capture & Resolution** group on the **Camera Sidebar** in ToupView. When the camera is opened, it is in **Video Mode** as shown in Figure 6-1 on the left. In **Video Mode**, **Auto Exposure**, **Exposure Target**, **Exposure Time** and **Gain** can be set. One can switch to **Trigger Mode** by checking the **Trigger Mode** check box.

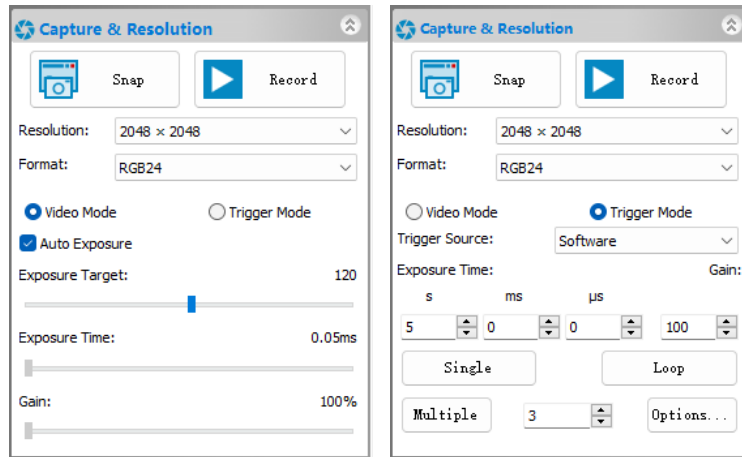

Figure 6-1 Video Mode and Trigger Mode on the Capture & Resolution group in ToupView

After the **Trigger Mode** is checked, the **Capture & Resolution** group will switch to **Trigger Mode** as shown in Figure 6-1 on the right. Where, the **Trigger Source**, **Exposure Time**, **Gain**, **Single**, **Loop**, **Multiple**, **Frame Box**, and **Options** can be set.

6.2 Trigger Sources and Their Capture Style

The **Trigger Source** can be any external input signal inputted into the camera which is called **Hardware (Trigger Source)**, it can also be a command from the application which is called **Software (Trigger Source)**. For the **Software Trigger Source**, it can be **Single**, **Loop**, **Multiple**, or **Sequence** style. Figure 6-2 shows the possible **Trigger Sources**. Table 6-1 shows the designed **Trigger Source** descriptions and possible capture styles for ToupTek camera.

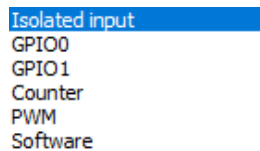
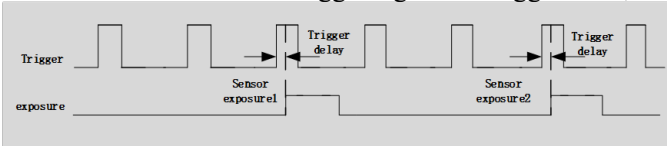
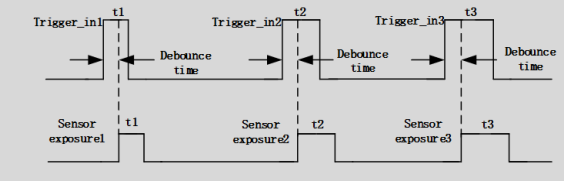
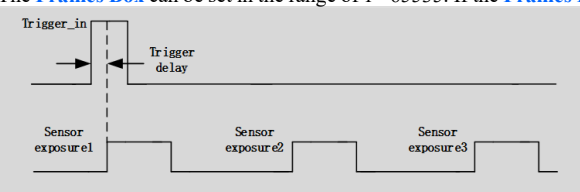

Figure 6-2 Possible Trigger Sources

Table 6-1 Description of possible Trigger Sources and their capture styles

Trigger Source	Description
Isolated input	Logic 0 input level: 0~2.2VDC; Logic 1 input level: 3.3~24VDC; Maximum input current: 30mA;
GPIO0	Logic 0 input level: 0~0.6VDC (DIR_GPIO0/DIR_GPIO1 pins); Logic 1 input level: 2.0~24VDC (DIR_GPIO0/DIR_GPIO1 pins); Maximum input current: 25mA; If GPIO0 is chosen as Trigger Source , it should be configured as Input in the GPIO Mode 's combo box on the Options>IO Control page;
GPIO1	Logic 0 input level: 0~0.6VDC (DIR_GPIO0/DIR_GPIO1 pins); Logic 1 input level: 2.0~24VDC (DIR_GPIO0/DIR_GPIO1 pins); Maximum input current: 25mA; If GPIO1 is chosen as Trigger Source , it should be configured as Input in the GPIO Mode 's combo box on the Options>IO Control page;
Counter	Counter refers to the operation mode in which the camera can divide the frequency of the external input trigger signal through the preset Counter Value and perform image acquisition according to the customer's logic. For example, when the counter value (Counter Value: <input type="text" value="3"/> [1,1023]) is set to 3, the

	<p>camera needs to receive 3 trigger signals to trigger once;</p>  <p>When Counter is chosen in Trigger Source combo box in the Capture & Resolution group, the Counter Source can be Isolated input, GPIO0 or GPIO1 which can be chosen on Options>IO Control page; If GPIO0 or GPIO1 is chosen in the Counter Source combo box on Options>IO Control page. It should be configured as Input in the GPIO Mode combo box; Check Options>IO Control page's Line Select related items and Counter related items for details;</p>
<p>PWM</p>	<p>PWM refers to the operation mode in which the camera exposure time is controlled by the input trigger signal's pulse width;</p>  <p>PWM Trigger Source can be Isolated input, GPIO0 or GPIO1. If GPIO0 or GPIO1 is chosen in the PWM Source combo box on the Options>IO Control page, it should be configured as Input in the GPIO Mode combo box; Check Options>IO Control page's Line Select related items and PWM related items for details;</p>
<p>Software</p>	<p>When Software trigger is chosen, the client software can send the command through USB3.0 to trigger, acquire and transfer images, In ToupView, Single, Loop, Multiple, or Sequence can be used to send the Software trigger command;</p> <p>If the Plan or Hardware is chosen in the Type combo box on the Options>Sequence page, the Multiple button will switch to Sequence button and the camera will use the Exposure Time and Gain in the Sequence table on this page one by one to capture the specified frames.</p> <p>Check Single, Loop, Multiple, or Sequence on Capture & Resolution group for the Software capture operations;</p> <p>Check Options>Sequence page and Options>Advanced page for the related Sequence and Software capture setup options;</p>
<p>Single</p>	<p>When Single is clicked, the camera will start to capture the image. At the same time the Single button will switch to Stop button. Clicking Stop button to stop the current Single capture operation, the Stop button will switch to Single button again for the next capture operation;</p> <p>Note:</p> <ol style="list-style-type: none"> 1) The captured frames will always Show in the video window to prevent too many captures; 2) Enabled when Software in the Trigger Source combo box is chosen or Always enable software trigger checkbox is checked on the Options>Advanced property page;
<p>Loop</p>	<p>When Loop is clicked, the camera will start to capture the image continuously and the Loop button will switch to Stop button. Clicking Stop button to stop Loop captures and the Stop button will switch to Loop button for the next Loop capture operation;</p> <p>Note:</p> <ol style="list-style-type: none"> 1)The captured frames will always Show in the video window to prevent too many captures; 2)Enabled to capture continually when Software in the Trigger Source combo box is chosen or Always enable software trigger checkbox is checked on the Options>Advanced property page;
<p>Multiple</p>	<p>Multiple refers to the operation mode in which the camera receives Software trigger signal or command and exports multiple frames of images. An edit box with spin(we call it Frames Box) is designed and affiliated to the Multiple button (Multiple <input type="text" value="3"/> Options...) for the setting of the frames to be captured;</p> <p>The Frames Box can be set in the range of 1~ 65535. If the Frames Box is 3, a three-frame image will be captured and exported;</p>  <p>Note:</p> <ol style="list-style-type: none"> 1)Multiple capture is enabled to capture continually when Software in the Trigger Source combo box is chosen; 2) Multiple capture is enabled when Always enable software trigger is checked on the Options>Advanced property page, no matter whether Trigger Source is Software or Hardware on the Capture & Resolution group; 3) If the Plan or Hardware is chosen in the Type combo box on the Options>Sequence page, the Multiple button will switch to Sequence button and the camera will use the Exposure Time and Gain in the Sequence table on this page. The captured frames will be displayed either in Show in the video window, or Show in a new window or Save to disk which can be specified on Options>Output page;
<p>Sequence</p>	<p>When Sequence is clicked, the camera will start to capture the image until the specified frames in the Frames Box are captured. At the same time the Sequence button will switch to Stop button. Clicking Stop button will stop the current Sequence capture and the Stop button will switch to Sequence again for the next Sequence capture operation;</p> <p>Note:</p> <ol style="list-style-type: none"> 1) Switched from Multiple to Sequence to capture the specified frames in the edit box with spin(Frames Box) when Plan or Hardware in the Type combo box is chosen on the Options>Sequence property page; 2)If the Plan or Hardware is chosen in the Type combo box on the Options>Sequence page, the Sequence button will be enabled and the capture will use the Exposure Time and Gain in the Sequence table list below one by one on the

Options>Sequence page;

3) If the **Plan** or **Hardware** is chosen in the **Type** combo box on the **Options>Sequence** page and **Always enable software trigger** is checked on the **Options>Advanced** property page, the **Sequence** button will not switch to **Multiple** button and will be enabled only when the still in Sequence enable

4) If the **Plan** is chosen in the **Type** combo box on the **Options>Sequence** page and the **Software** is chosen in the **Trigger Source** combo box, the **Sequence** button will be enabled.

5) If the **Hardware** is chosen in the **Trigger Source** combo box, the **Sequence** button will be disabled, but the **Frame Box** will still be enabled and the **Sequence** will switch to the **Hardware Sequence** capture. One **Hardware** trigger signal will capture the specified frames on the **Frame Box** using the **Exposure Time** and **Gain** in the **Sequence table** on **Options>Sequence** page;

6) Check **Options>Sequence** page for the related **Sequence** setup options;

6.3 The trigger capture and IO Control configurations

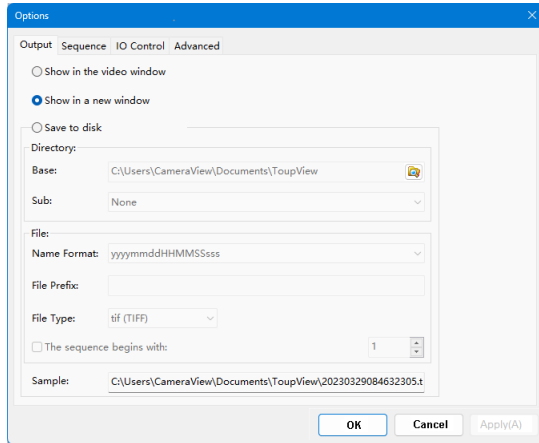

Figure 6-3 Options>Output page

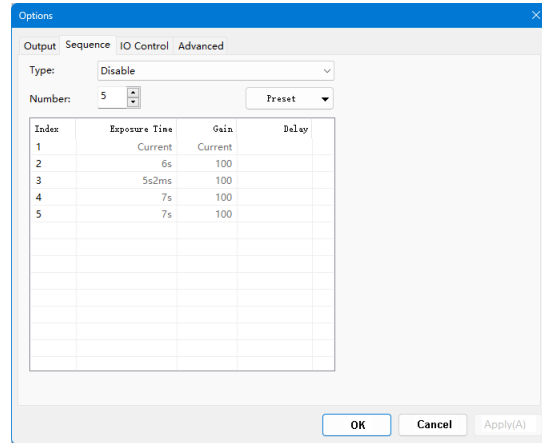

Figure 6-4 Options>Sequence page

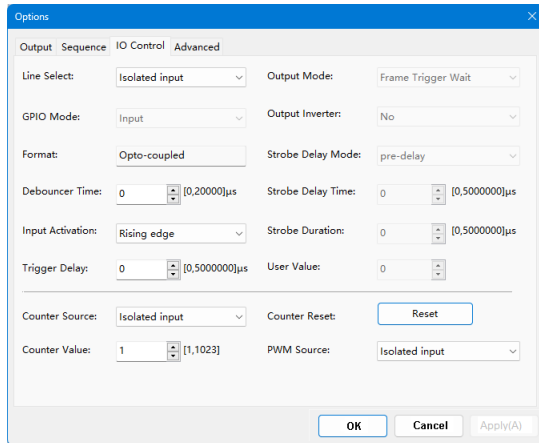

Figure 6-5 Options>IO Control page

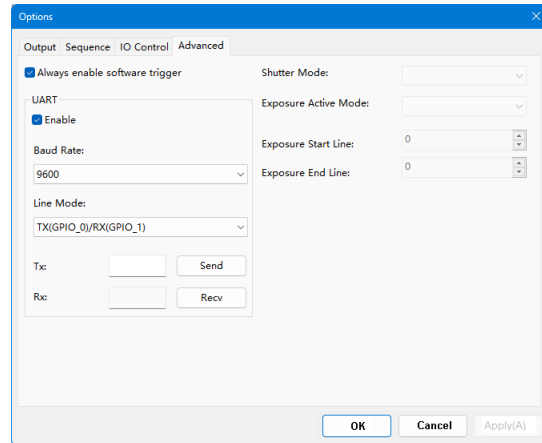

Figure 6-6 Options>Advanced page

The **Trigger Source** can be **Isolated input**, **GPIO0**, **GPIO1**(when configured as input), **Counter**, or **PWM** which can be configured on the **Options** property sheet. Also the camera's **Isolated output**, **GPIO0** or **GPIO1**(can be configured as **Output**) can be used as **Output** or **UART** (**GPIO0**, **GPIO1** only) applications. All of these configurations can be realized on the **Options** property sheet described in Table 6-2 below.

About the captured file operation style, one can find it on the **Option>Output** page;



About the **Sequence** setup, one can find it on the **Option>Sequence** page;

About the camera pin **IO Control** style, one can find it on the **Options>IO Control** page;

About the **Always enable software trigger** and **UART** setup, **Shutter Mode**, and **Exposure Active Mode**, one can find it on the **Options>Advance** page.

Table 6-2 Options property sheet for Trigger Source or camera pin configuration

Pages	Items	Descriptions
-------	-------	--------------

Output page	Output Destination	<p>Used to set the captured frame's Output destination, can be Show in the video window, Show in a new window or Save to disk;</p> <p>When Save to disk is checked, the  button will be enabled clicking it to choose the Base directory, clicking the Sub combo box's dropdown button to choose the Sub directory;</p> <p>The File Name Format, File Prefix, File Type, and even The sequence begin with can be chosen, set, or defined.</p> <p>Note:</p> <ol style="list-style-type: none"> 1)Valid only for Sequence or Multiple capture setup; 2)For Single or Loop capture, the captured image will be always displayed on the video window;
Sequence page	<p>Type</p> <p>Disable</p> <p>Plan</p> <p>Hardware</p>	<p>Disable: If the Disable button is chosen in the Type combo box on the Options>Sequence page, the Sequence button on the Capture & Resolution page will switch to Multiple button;</p> <p>Plan: 1)If Plan is chosen in the Type combo box on the Options>Sequence page, the Multiple button on the Capture & Resolution group will switch to Sequence button;</p> <p>2) If the Software Trigger Source is chosen in the Capture & Resolution group or the Always enable software trigger is checked on the Options>Advanced property page, the Sequence button will be enabled After the Software trigger signal is arrived(By clicking Single, Loop, or Sequence button), the camera will capture frames specified in the edit box with spin  Sequence 3  (we call it Frames Box) affiliated to the Sequence button; The whole captures will use the Exposure Time, Gain and Delay in the Sequence table list under  Number: 3  one by one by the software;</p> <p>3) If the Disable button is chosen in the Type combo box on the Options>Sequence page, the Sequence button on the Capture & Resolution page will switch to Multiple button;</p> <p>4) The Sequence button will be enabled only when a) the Plan in the Type combo box is chosen on the Options>Sequence page and b) he Software Trigger Source is chosen in the Capture & Resolution group or c) Always enable software trigger is checked on the Options>Advanced property page;</p> <p>Hardware: 1) if Hardware is chosen in the Type combo box on the Options>Sequence page, the Multiple button on the Capture & Resolution group will switch to Sequence button and will be disabled for Hardware trigger. But users can still set the frames number in the Frame Box on the Capture & Resolution group;</p> <p>2) After the Hardware trigger signal arrives, the camera will capture frames specified in the edit box with spin  Sequence 3  (we call it Frame Box) affiliated to the Sequence button; The whole capture will use the Exposure Time, Gain (Delay is not used) in the Sequence table list under  Number: 3  one by one but stored in the camera hardware for the quick operation;</p> <p>3) If the Disable button is chosen in the Type combo box on the Options>Sequence page, the Sequence button on the Capture & Resolution page will switch to Multiple button.</p> <p>4) The Sequence button is always disabled if a) The Hardware is chosen in the Type combo box on the Options>Sequence page and b)the Hardware Trigger Source is chosen in the Capture & Resolution group;</p> <p>5) The Sequence button will be enabled if a) the Software Trigger Source is chosen in the Capture & Resolution group or b) the Always enable software trigger checkbox is checked on the Options>Advanced property page, in this case, both the Plan and Hardware Sequence capture are supported;</p>
	Number	The possible Sequence (capture) frames to be captured. If the Number is larger than the Sequence Number in the Frames Box on the Capture & Resolution group, the other Indices will be executed at the next Sequence operation one by one recycled;
	Index	The order of the Number group;
	Exposure Time	The camera Exposure Time for the specified capture Index in the Sequence capture;
	Gain	The camera Gain for the specified capture Index in the Sequence capture;
	Delay	The Delay time for the specified capture Index in the Plan Sequence capture(Valid for Plan Sequence capture only);
	Preset	Choosing Save to save the current Sequence table 's settings; Clicking Management to Rename the saved Sequence table 's setting files or Remove them from the Management list;
IO Control page	Line Select	Choosing which line to set. Can be Isolated input , Isolated output , GPIO0 or GPIO1 et al;
	GPIO Mode	To configure whether the line selected in Line Select is for Input or Output . Only GPIO0 or GPIO1 can be configured as either Input or Output ;
	Format	Specify the current selected signal's Format in the Line Select combo box, can be Opto-coupled(Isolated input, Isolated output) or TTL (GPIO0 or GPIO1) for clarity(Unconfigurable);
	Debouncer Time	<p>Since there may be a glitch in the external trigger input signal if it directly enters into the internal logic circuit of the camera, it will cause false triggering, so the input trigger signal should be debounced. In addition, the effective pulse width of the trigger signal input by the user should be greater than the Debouncer Time, otherwise, the trigger signal will be ignored;</p> <p>When Isolated input, GPIO0 or GPIO1 is chosen in the Line Select combo box and GPIO0 or GPIO1 is configured as Input in the GPIO Mode combo box, the Debouncer Time will be enabled for the user to input the Debouncer Time between 0 to 20000us;</p> 

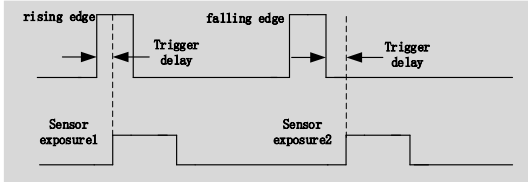
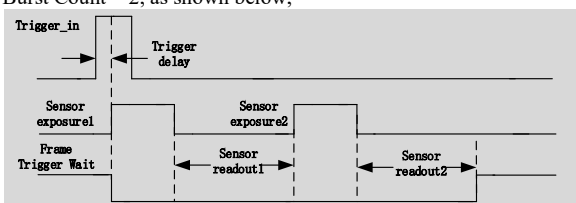
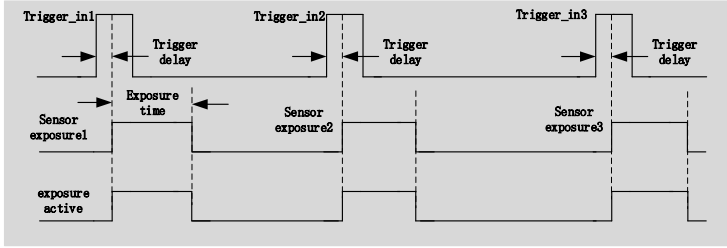
<p>Input Activation</p>	<p>When Isolated input, GPIO0 or GPIO1 is chosen in the Line Select combo box and GPIO0 or GPIO1 is configured as Input in the GPIO Mode combo box; The Input Activation combo box will be enabled to configure the Input Activation as either Rising Edge or Falling Edge;</p>  <p>Also can be configure as high level or low level. When high level is selectd, the camera keeps triggering the frame when the input signal is high; When low level is selectd, the camera keeps triggering the frame when the input signal is low;</p>								
<p>Trigger Delay</p>	<p>When Isolated input, GPIO0 or GPIO1 is chosen in the Line Select combo box and GPIO0 or GPIO1 is configured as Input in the GPIO Mode combo box, the Trigger Delay will be enabled for the user to input the Trigger Delay time between 0 to 5000000us;</p> <p>If the Trigger Delay time is set to 1000000us, the camera will wait for 1s to capture the image after receiving the trigger signal;</p>								
<p>Output Mode</p> <ul style="list-style-type: none"> Frame Trigger Wait Exposure Active Strobe User Output Counter Output Timer Output 	<p>When Isolated output, GPIO0 or GPIO1 is selected in the Line Select combo box and GPIO0 or GPIO1 is configured as Output in the GPIO Mode combo box, the Output Mode will be enabled. It can be Frame Trigger Wait, Exposure Active, Strobe, User Output, Counter Output or Timer Output. The chosen mode can be used for diversified applications;</p> <p>The Frame Trigger Wait signal is pulled low at the start of exposure and pulled high when the last frame of data is read out. The trigger signal input by the user should be in the valid period. If the user inputs a trigger signal when the signal is low, the trigger signal input at this time will be ignored. The following example is the case when Burst Count = 2, as shown below;</p>  <p>Exposure Active: when this signal is high, it means the sensor is exposing. This signal can be used to control an external mobile device to remain stationary or move at low speed while the camera is at exposure. The timing diagram of the exposure valid signal is shown below;</p>  <p>When the relative position of the camera and the object to be photographed changes, you can refer to Exposure Active signal to prevent the captured image from being affected by movement and focus adjustment during the exposure process;</p> <p>When Strobe is chosen, Strobe Delay Mode, Strobe Delay Time, Strobe Duration will be enabled;</p> <p>When User Output is chosen, User Value will be enabled. lines3, line2, line1 are the combination of GPIO1, GPIO0 and Isolated output respectively. If User Value is 001, then line GPIO1 and GPIO0 will be disabled and Isolated output will be enabled;</p> <table border="1" data-bbox="459 1579 702 1668"> <tr> <td>UserOutput Value:</td> <td>1</td> <td>0</td> <td>0</td> </tr> <tr> <td>Line:</td> <td>line3</td> <td>line2</td> <td>line1</td> </tr> </table> <p>When the Counter Output is selectd, when the counter value is "m", the camera triggers "m" times to output a signal.</p> <p>When the Timer Output is selectd, the camera keeps output signals. When the Strobe Delay Time is delay, the pulse width of the high level is determined by the Strobe Duration. The pulse width of low level is determined by the Strobe Delay Time.</p>	UserOutput Value:	1	0	0	Line:	line3	line2	line1
UserOutput Value:	1	0	0						
Line:	line3	line2	line1						
<p>Output Inverter</p>	<p>When Isolated output, GPIO0 or GPIO1 is selected in the Line Select combo box and Output is chosen for GPIO0 or GPIO1 in the GPIO Mode combo box, the Output Inverter will be enabled to configure the current selected line's output as either inverted or not(Yes or No).</p>								
<p>Strobe Mode</p>	<p>Strobe can be used to control external devices such as the strobe, and the effective level duration, delay time, and pre-delay time of the strobe signal can be set;</p> <p>When the Output Mode is Strobe, Strobe Delay Mode will be enabled. It can be pre-delay or delay;</p>								
<p>Strobe Time</p>	<p>When exposure starts, the strobe does not take effect immediately, and the output is delayed according to the value set by Strobe Delay Time which is between 0 to 5000000us. The Strobe Delay Mode can be pre-delay or delay; It is described below;</p>								

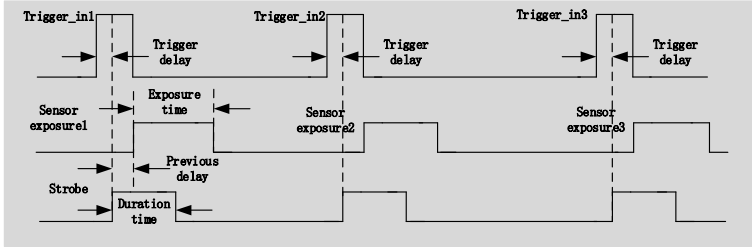
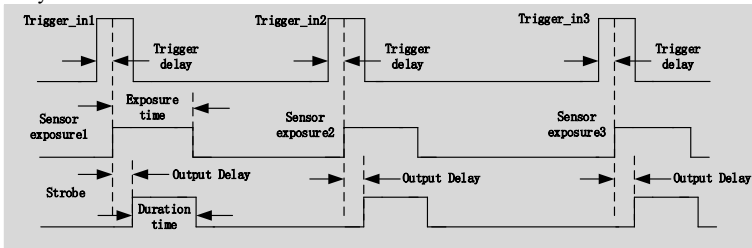
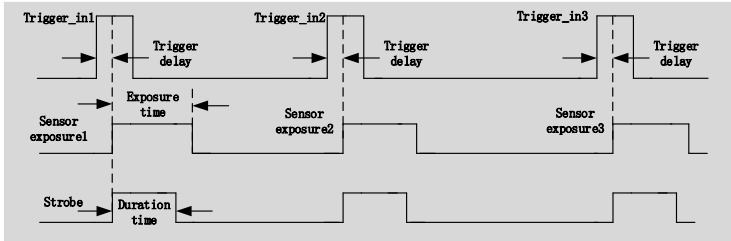
		<p>pre-delay:</p>  <p>delay:</p> 												
	<p>Strobe Duration</p>	<p>The high level duration of the strobe is determined by the Strobe Duration which is between 0 to 5000000us as shown below;</p> 												
	<p>User Value</p>	<p>Users can input a value at User Value edit box with spin to control the line as disable or enable. Enabled when User Output is chosen in the Output Mode combo box. The logical value 0 or 1's combination of GPIO1(line3), GPIO0(line2) and Isolated output(line1); When the output mode is selected as User Output, the user can input a value at User Value edit box to control the corresponding line output with 0 or 1; The value here is only valid for the lower three bits of a binary. For example, when line 1 and line 3 are set to User Output mode, and its User Value is set to 4 ('b100), then line 3 outputs 1, and line 1 outputs 0, as shown below.</p> <table border="1" data-bbox="459 1240 703 1330"> <tr> <td></td> <td></td> <td></td> <td>LSB</td> </tr> <tr> <td>UserOutput Value:</td> <td>1</td> <td>0</td> <td>0</td> </tr> <tr> <td>Line:</td> <td>line3</td> <td>line2</td> <td>line1</td> </tr> </table>				LSB	UserOutput Value:	1	0	0	Line:	line3	line2	line1
			LSB											
UserOutput Value:	1	0	0											
Line:	line3	line2	line1											
	<p>Counter Source</p>	<p>When Counter is chosen in the Trigger Source combo box in the Capture & Resolution group, the Counter Source can be chosen from Isolated input, GPIO0 or GPIO1 in this combo box on the Option>IO Control page;</p>												
	<p>Counter Value</p>	<p>The Counter Value is used to divide the frequency of the external input trigger signal when the Counter Trigger Source is chosen in the Capture & Resolution group; See Counter in Table 6-1 for detail;</p>												
	<p>Counter Reset</p>	<p>Click Reset button can clear the current counting process and begin a new one;</p>												
	<p>PWM Source</p>	<p>When PWM is chosen in the Trigger Source combo box in the Capture & Resolution group, the PWM Source can be from Isolated input, GPIO0, or GPIO1 in this combo box et al. ;</p>												
<p>Advanced page</p>	<p>Always enable software trigger</p>	<p>When this button is checked, no matter whether Trigger Source is Software or Hardware, the software trigger buttons(Single, Loop, Multiple) are always enabled; If the Plan or Hardware is chosen in the Type combo box on the Options>Sequence page, the Multiple button will switch to Sequence button; The Sequence button will be enabled if a)the Software Trigger Source is chosen in the Capture & Resolution group or b) the Always enable software trigger checkbox is checked on the Options>Advanced property page, in this case, both the Plan and Hardware Sequence captures are supported;</p>												
	<p>UART</p>	<p>There is a serial port function on the Advanced page, which can be used to communicate with external devices via serial port. Check Enable to enable this function. When enabled, GPIO0 and GPIO1 can only be used as UART transfers; The Baud Rate supports 9600-115200. Cable Select can configure GPIO0 and GPIO1, which can be configured as TX or RX respectively. Setting a value at TX, clicking Send to send the set value out; click Accept at RX to receive the value from the external device;</p>												
	<p>Shutter Mode</p>	<p>Enabled if the camera supports. Users can select Rolling Shutter or Global Reset;</p>												
	<p>Exposure Active Mode</p>	<p>Enabled if the camera supports. Users can select Specified lines or Common exposure time;</p>												
	<p>Exposure Start Line</p>	<p>Enabled when Specified lines in the Exposure Active Mode combo box is selected. To configure when the Exposure Active signal is valid;</p>												

	Exposure End Line	Enabled when Specified lines in the Exposure Active Mode combo box is selected. To configure when the Exposure Active signal is invalid;
--	--------------------------	--

8 Application

8.1 Application installation

In terms of software, customers are welcome to visit our website: <https://www.ehd.de> to download the latest EHDView, also be used with ASCOM, DirectShow interface. If the third-party software is compatible with these interfaces, customers can also download software drivers from our website and install them into the third-party software.

8.2 Introduction to ToupView

EHDView is a professional software that integrates camera control, image acquisition and processing, image browsing and analysis functions. EHDView has the following characteristics:

- x86: XP SP3 and above ; CPU supports SSE2 and above
- x64: Win7 and above
- Support video mode and Trigger Mode (Raw format or RGB format)
- Automatic capture and quick recording capabilities
- Supports multiple languages
- Hardware ROI and digital binning capabilities
- Rich image processing functions, such as image stitching, real-time overlay, flat field correction, dark field correction, etc.
- Supports all EHD SCA, SCM, SCC, SC, MaxCam cameras

8.2.1 User interface design

- The menus and toolbars are properly set to ensure quick operation
- Professionally integrated with 5 sidebars - Camera, Folders, Undo/Redo, Layers, Measure
- Comfortable operation method (double-click or right-click context menu)
- Detailed help manual

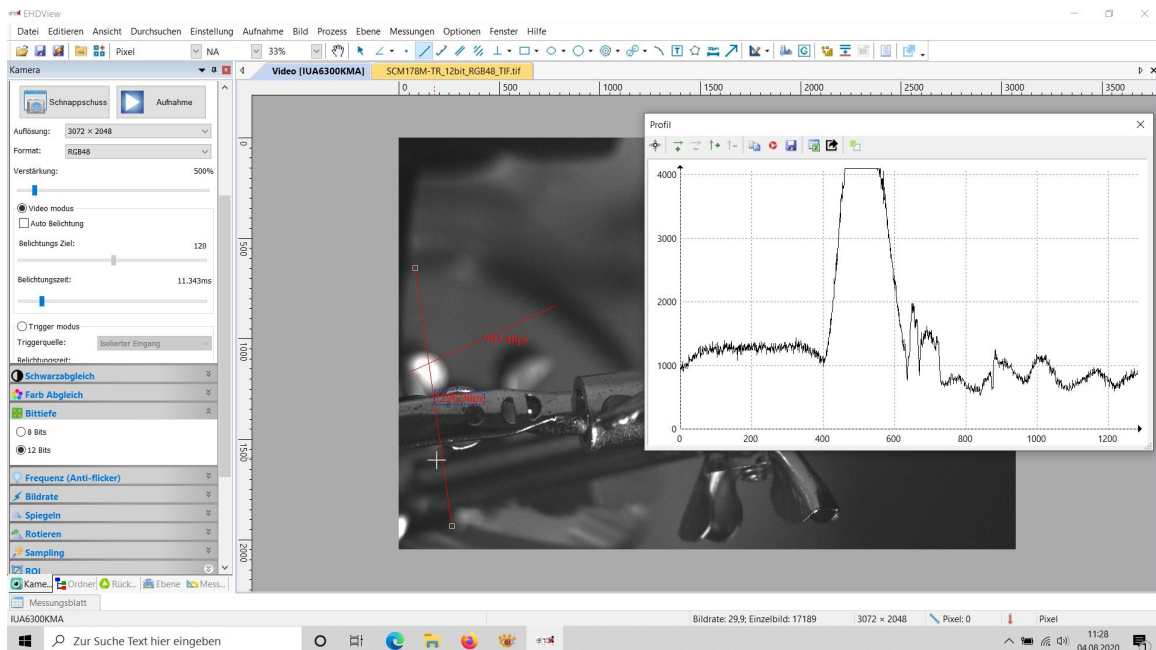

Figure 8-1 EHDView video window

8.2.2 Professional Camera Control Sidebar

Capture & Resolution	Set up live and still capture, snap images, or record video
Exposure & Gain	Auto exposure (preset exposure target value), manual exposure (exposure time can be manually entered and set by slider); gain up to 5 times
White Balance	Advanced one-click smart white balance settings, and you can adjust white balance by manually setting

	color temperature and color
Color Adjustment	Color, saturation, brightness, contrast, gamma initial high-speed adjustment function
Frame Rate Control	For different computer and USB performance, the camera can be super compatible by adjusting the frame rate
Flip	Select "Horizontal" or "Vertical" to adjust the sample orientation to ensure the same orientation as the visual system
Sampling	Neighborhood averaging can improve the signal-to-noise ratio of the video stream; while the sampling extraction mode can ensure the sharpness of the video stream. Supports histogram expansion of video stream, image negative and positive switching, grayscale calibration, and sharpness factor calculation to facilitate video focusing
Bit Depth	8, 12-bit switching, 8-bit is the basic Windows image format. 12-bit has higher image quality but reduces frame rate
Roi	ROI, Region of interest. This function can set the ROI value of the video window. After the ROI group is expanded, a rectangular box will appear in the middle of the video window, and the ROI can be changed. The mouse can adjust the size of the ROI. If there is no problem with the ROI, click "Apply" to set the video to the size of the ROI, and the default value will be restored to the original size.
Dark Field Correction	To enable darkfield correction, you should first capture a field image, then click Enable. Check Enable to enable darkfield correction. Uncheck it to disable darkfield correction
Cooling	Set TEC Target Temperature, fan on/off
Parameter Save	Load, save, overwrite, load, export custom camera panel controls (including calibration information, exposure parameters and color settings information, etc.)

8.2.3 Professional and practical image processing functions

Video Function	Various video professional processing functions: video broadcasting, timing capture, video recording, video watermarking, watermark mobile alignment, watermark rotation alignment, video grid overlay, video measurement, video scaling, gray scale calibration, video high dynamic (HDR), video depth of field extension, video image stitching, video scale, date, etc.
Image Processing and Enhancement	Image contrast control and adjustment, image denoising, various image filtering algorithms, image mathematical morphology algorithms, image rotation, image scaling and image printing, etc.
Image Overlay	The ToupView image overlay denoising function introduces advanced image matching technology. Users only need to record a short video of the image to be superimposed, and they can superimpose and output high fidelity in the case of displacement, rotation and magnification change between multiple frames of the video. images, easy to use

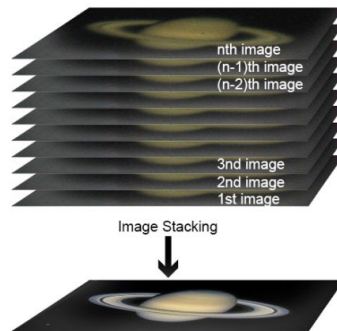

Figure 8-2 Image overlay denoising

8.2.4 Super compatibility

Camera Video Interface	Provide Twain, DirectShow, Labview, SDK installation package (native C++, C#)
Supported Platform and architectures	Compatible with Microsoft® Windows® XP / Vista / 7 / 8 /10 /11(32 & 64 bit), Mac OSX, Linux
Language Support	Language support can be added manually, currently supports English, Simplified Chinese, Traditional Chinese, German, Japanese, Russian, French, Italian, Polish, Turkish

8.2.5 Basic hardware requirements

PC Basic Configuration Requirements	CPU: Intel Core 2 2.8GHz or higher
	RAM: 2GB or more
	USB Port: USB3.0 / USB 2.0
	Monitor: 17" or higher
	CD-ROM

9 Software development instructions

9.1 SDK description

The download link of the SDK is as follows:

<https://www.ehd.de>

9.1.1 SDK support platform

- Win32:
 - x86: XP SP3 and above; the CPU needs to support at least the SSE2 instruction set.
 - x64: Win7 and above.
 - arm: Win10 and above.
 - arm64: Win10 and above.
- WinRT: x86, x64, arm, arm64; Windows 10 and above.
- macOS: x86 and x64 bundle; macOS 10.10 and above.
- Linux: core 2.6.27 and above.
 - x86: The CPU needs to support at least the SSE3 instruction set; GLIBC 2.8 and above.
 - x64: GLIBC 2.14 and above.
 - armel: GLIBC 2.17 and above; compiled by toolchain arm-linux-gnueabi (version 4.9.2).
 - armhf: GLIBC 2.17 and above; compiled by toolchain arm-linux-gnueabi (version 4.9.2).
 - arm64: GLIBC 2.17 and above; compiled by toolchain aarch64-linux-gnu (version 4.9.2).
- Android: arm, arm64, x86, x64; compiled by android-ndk-r18b.

9.1.2 Introduction to SDK content

EHD series cameras support a variety of APIs, including: Native C/C++, .NET/C#/VB.NET, Python, Java, DirectShow, Twain, LabView, Matlab, etc. Compared with other APIs, Native C/C++ API as a low-level API is characterized by using pure C/C++ development without relying on other runtime libraries. The interface is simple and the control is flexible. This SDK zip package contains all the resources and information needed. The directory is as follows:

- inc:
 - nncam.h, the C/C++ header file.
- win: Microsoft Windows platform file
 - ◆ dotnet:
 - nncam.cs, supports C#. toupcam.cs uses P/Invoke to call nncam.dll. Please copy nncam.cs to your C# project for use.
 - nncam.vb, supports VB.NET. nncam.vb uses P/Invoke to call nncam.dll. Please copy nncam.vb to your VB.NET project for use.
 - ◆ x86:
 - nncam.lib, x86 lib file.
 - nncam.dll, x86 dynamic library file.
 - democpp.exe, x86 C++ demo execute the procedure.
- x64:
 - nncam.lib, x64 lib file.
 - nncam.dll, x64 dynamic library file.
 - democpp.exe, x64 C++ demo execute the procedure.
- arm:
 - nncam.lib, arm lib file.

nncam.dll, arm dynamic library file.

- arm64:
nncam.lib, arm64 lib file.
nncam.dll, arm64 dynamic library file.
- winrt:
They can be applied for Dynamic library files of WinRT/ UWP (Universal Windows Platform)/ Windows Store App. They are compatible with Windows Runtime and can be referenced by Universal Windows Platform apps. If you use C# to develop UWP, you can use the `toupcam.cs` wrapper class. Please pay attention to the Device Capability of uwp. Refer to how to add USB device capabilities to the app manifest. (Microsoft seems to limit the Device entry under DeviceCapability to no more than 100) `demouwp.zip` is a simple example of uwp. Please modify `vid` and `pid`. under DeviceCapability in the file `Package.appxmanifest` before compiling the run example.
- Drivers: (Cameras produced after 2017.1.1 support WinUSB, and drivers no longer need to be installed on Windows 8 and above)

The x86 folder contains the x86 kernel-mode driver files, including `nncam.cat`, `nncam.inf` and `nncam.sys`.

The x64 folder contains the x64 kernel-mode driver files, including `nncam.cat`, `nncam.inf` and `nncam.sys`.

- samples:
 1. `democpp`, C++ example. This example demonstrates enumerating devices, opening devices, previewing videos, capturing images, setting resolution, triggering, saving images to files in various image formats (.bmp,.jpg,.png, etc.), `wmv` format video recording, Trigger Mode/Trigger Mode, IO control and so on. This example uses the Pull Mode mechanism. To keep the code clean, the WTL library used by the examples can be downloaded from this link <http://sourceforge.net/projects/wtl/>.
 2. `demopush`, C++ example, using the Push Mode mechanism, `StartPushModeV3`.
 3. `demomfc`, a simple C++ example, uses MFC as a GUI library, supports opening devices, previewing videos, capturing images, setting resolution, saving images to files in various image formats (.bmp,.jpg,.png, etc.), etc. This example uses the Pull Mode mechanism.
 4. `demowinformcs1`, take C# `winform` for example, it supports opening devices, previewing videos, capturing images, saving images to files, and setting white balance. This example uses the Pull Mode mechanism, `StartPullModeWithWndMsg`.
 5. `demowinformcs2`, take C# `winform` for example, it supports opening devices, previewing videos, capturing images, saving images to files, and setting white balance. This example uses the Pull Mode mechanism, `StartPullModeWithCallback`.
 6. `demowinformcs3`, take C# `winform` for example, it supports opening devices, previewing videos, capturing images, saving images to files, and setting white balance. This example uses the Push Mode mechanism, `StartPushMode`.
 7. `demowinformvb`, take VB.NET `winform` for example, it supports opening devices, previewing videos, capturing images, saving images to files, and setting white balance. This example uses the Pull Mode mechanism.
- linux: Linux platform files
Udev: `99-toupcam.rules`, udev rule file.
Please refer to: http://reactivated.net/writing_udev_rules.html.
- c#: `toupcam.cs`, Support. Net Core C#. `toupcam.cs` uses `P/Invoke` to call `libtoupcam.so`. Please copy `toupcam.cs` to your C# project for use.
- x86: `libnncam.so`, x86 version so file.
- x64: `libnncam.so`, x64 version so file.
- armel: `libnncam.so`, armel version so file, toolchain is `arm-linux-gnueabi`.
- armhf: `libnncam.so`, armhf version so file, toolchain is `arm-linux-gnueabi`.

- arm64: libnncam.so, arm64 version so file, toolchain is aarch64-linux-gnu.
- android: libnncam.so for four architectures of Android platform arm, arm64, x86, x64.
- mac: macOS platform files.
- python: nncam.py and example code.
- java: toupcam.java and example code (console and Swing).
- doc: SDK usage documentation, Simplified Chinese, English.
- sample:
- de emosimplest, the simplest example, is about 60 lines of code.
- demoraw, RAW data and still shots, about 120 lines of code.
- extras:
- directshow: DirectShow SDK and demo program.
- twain: TWAIN SDK.
- labview: Labview SDK and demo program.
- matlab: MatLab demo program.

EHD imaging GmbH
Zum Rennplatz 15
D-49401 Damme (Germany)
Tel: +49-5491-2090
email: info@ehdimaging.de
web: www.ehd.de

